

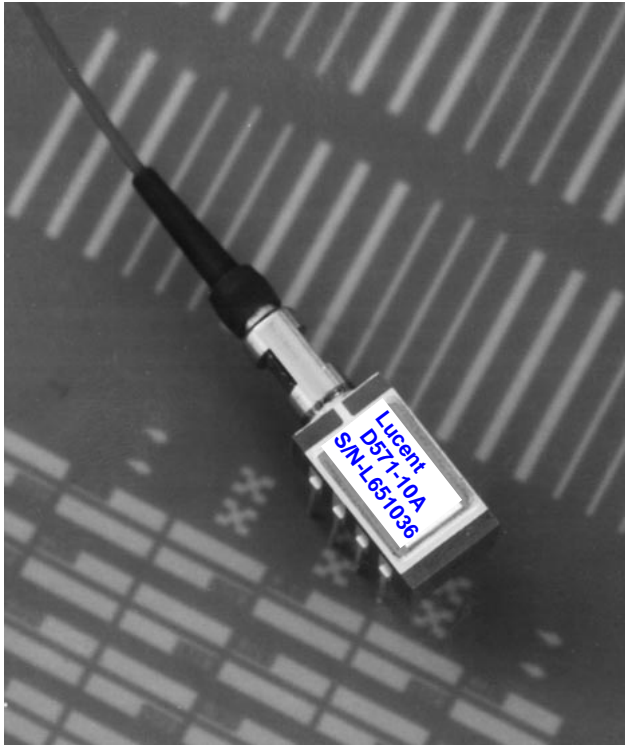

D571-Type Digital 1.5 μm Uncooled DFB *FastLight*TM Laser Module



The low-profile D571-Type Laser Module is ideally suited for short- and long-haul SONET and other high-speed digital applications.

Features

- Eight-pin package suitable for SONET/SDH applications
- Narrow linewidth, distributed-feedback, multiquantum-well (DFB-MQW), 1510 nm or 1550 nm laser with single-mode fiber pigtail
- Available in narrow and wide temperature ranges
- No TEC required
- High output power:
 - Typical 2.0 mW peak power coupled into single-mode fiber
 - 1.0 mW devices are also available

- Hermetically sealed active components
- Internal back-facet monitor
- Qualification program: *Telcordia Technologies* * TA-983

* *Telcordia Technologies* is a trademark of Bell Communications Research, Inc.

Applications

- Long-reach SONET OC-3/STM-1, OC-12/STM-4 systems
- Telecommunications
- Secure digital data systems

Benefits

- Easily board mounted
- Requires no lead bending
- No additional heat sinks required
- Pin compatible with industry-standard 14-pin laser module
- Highly efficient DFB-MQW laser structure allows for lower threshold and drive currents, and reduced power consumption

Description

The D571-Type Uncooled Laser Module consists of a laser diode coupled to a single-mode fiber pigtail. The device is available in a standard, 8-pin configuration (see Figure 1 and/or Table 1) and is ideal for long-reach (SONET) and other high-speed digital applications.

The laser diode is a narrow linewidth (<1 nm) DFB-MQW single-mode laser and an InGaAs PIN photodiode back-facet monitor in an epoxy-free, hermetically sealed package.

Description (continued)

The device characteristics listed in this document are met at 2.0 mW output power. Higher- or lower-power operation is possible. Under conditions of a fixed photodiode current, the change in optical output is typically ± 0.5 dB over an operating temperature range of -40 $^{\circ}\text{C}$ to $+85$ $^{\circ}\text{C}$.

This device incorporates the new Laser 2000 manufacturing process developed by the Optoelectronic unit of Lucent Technologies Microelectronics Group. Laser 2000 is a low-cost platform that targets high-volume manufacturing and tighter product distributions on all optical subassemblies. The platform incorporates an advanced optical design that is produced on a highly automated production line. The Laser 2000 platform is

qualified for the central office and uncontrolled environments, and can be used for applications requiring high performance and low cost.

Table 1. Pin Descriptions

Pin Number	Connection
1	NC/Reserved
2	Case ground
3	NC/Reserved
4	Photodiode cathode
5	Photodiode anode
6	Laser diode cathode
7	Laser diode anode
8	NC/Reserved

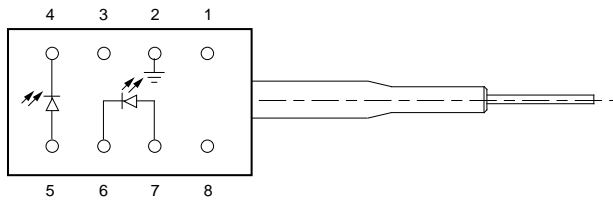

1-900 (C)

Figure 1. D571-Type Digital Uncooled DFB Flat-PAC Laser Module Schematic, Top View

Absolute Maximum Ratings

Stresses in excess of the absolute maximum ratings can cause permanent damage to the device. These are absolute stress ratings only. Functional operation of the device is not implied at these or any other conditions in excess of those given in the operations sections of the data sheet. Exposure to absolute maximum ratings for extended periods can adversely affect device reliability.

Parameter	Symbol	Min	Max	Unit
Maximum Peak Laser Drive Current or Maximum Fiber Power*	I_{OP} P_{MAX}	—	150 10	mA mW
Peak Reverse Laser Voltage:				
Laser	V_{RL}	—	2	V
Monitor	V_{RM}	—	20	V
Monitor Forward Current	I_{FD}	—	2	mA
Operating Case Temperature Range	T_C	-40	85	$^{\circ}\text{C}$
Storage Case Temperature Range	T_{stg}	-40	85	$^{\circ}\text{C}$
Lead Soldering Temperature/Time	—	—	260/10	$^{\circ}\text{C}/\text{s}$
Relative Humidity (noncondensing)	RH	—	85	%

* Rating varies with temperature.

Handling Precautions

CAUTION: This device is susceptible to damage as a result of electrostatic discharge (ESD). Take proper precautions during both handling and testing. Follow guidelines such as JEDEC Publication No. 108-A (Dec. 1988).

Although protection circuitry is designed into the device, take proper precautions to avoid exposure to ESD.

Electro-Optical Characteristics

Table 2. Electro-Optical Characteristics (over operating temperature range unless otherwise noted)

Parameter	Symbol	Test Conditions	Min	Typ	Max	Unit
Operating Temperature Range	T	—	-40	—	85	$^{\circ}\text{C}$
Optical Output Power*	P_F	CW, nominal	—	2	—	mW
Threshold Current	I_{TH}	T = 25 $^{\circ}\text{C}$	5	—	15	mA
		T = full range	2	—	60	mA
		T = -10 $^{\circ}\text{C}$ to + 70 $^{\circ}\text{C}$	2	—	50	mA
Modulation Current	I_{MOD}	CW, $P_F = 2.0$ mW, T = 25 $^{\circ}\text{C}$	15	—	35	mA
		CW, $I_{MON} = \text{constant}$, T = full range	7.5	—	60 [†]	mA
Slope Efficiency [‡]	SE	CW, $P_F = 2.0$ mW, T = 25 $^{\circ}\text{C}$	57	—	133	$\mu\text{W}/\text{mA}$
Center Wavelength	λ_c	$P_F = 2.0$ mW, CW	1525	—	1570	nm
Center Wavelength 1510 nm codes	λ_c	$P_F = 2.0$ mW, CW	1500	—	1520	nm
Spectral Width (-20 dB)	$\Delta\lambda$	$P_F = 2.0$ mW, 622 Mbits/s	—	—	1	nm
Side-mode Suppression Ratio	SMSR	CW, $P_F = 2.0$ mW	30	40	—	dB
Tracking Error	TE	$I_{MON} = \text{constant}$, CW	-1.5	—	1.5	dB
Spontaneous Emission	P_{TH}	$I = (0.9) I_{TH}$	—	—	100	μW
Rise/Fall Times	t_R, t_F	10%—90% pulse T = 25 $^{\circ}\text{C}$	—	0.25	0.5	ns
Forward Voltage	V_F	CW	—	1.1	1.6	V
Input Impedance	R	—	3	—	8	Ω
Monitor Current	I_{MON}	$V_R^{\S} = 5$ V	100	—	1000	μA
Monitor Dark Current	I_D	$V_R^{\S} = 5$ V	—	10	200	nA
Wavelength Tempera- ture Coefficient	—	—	—	0.09	0.12	$\text{nm}/^{\circ}\text{C}$

* 1mW power option also available. See Table 4 for more information.

[†] BOL value; EOL = 80 mA.

[‡] The slope efficiency is used to calculate the modulation current for a desired output power. This modulation current plus the threshold current comprise the total operating current for the device.

[§] V_R = reverse voltage.

Outline Diagram

Dimensions are in inches and (millimeters)

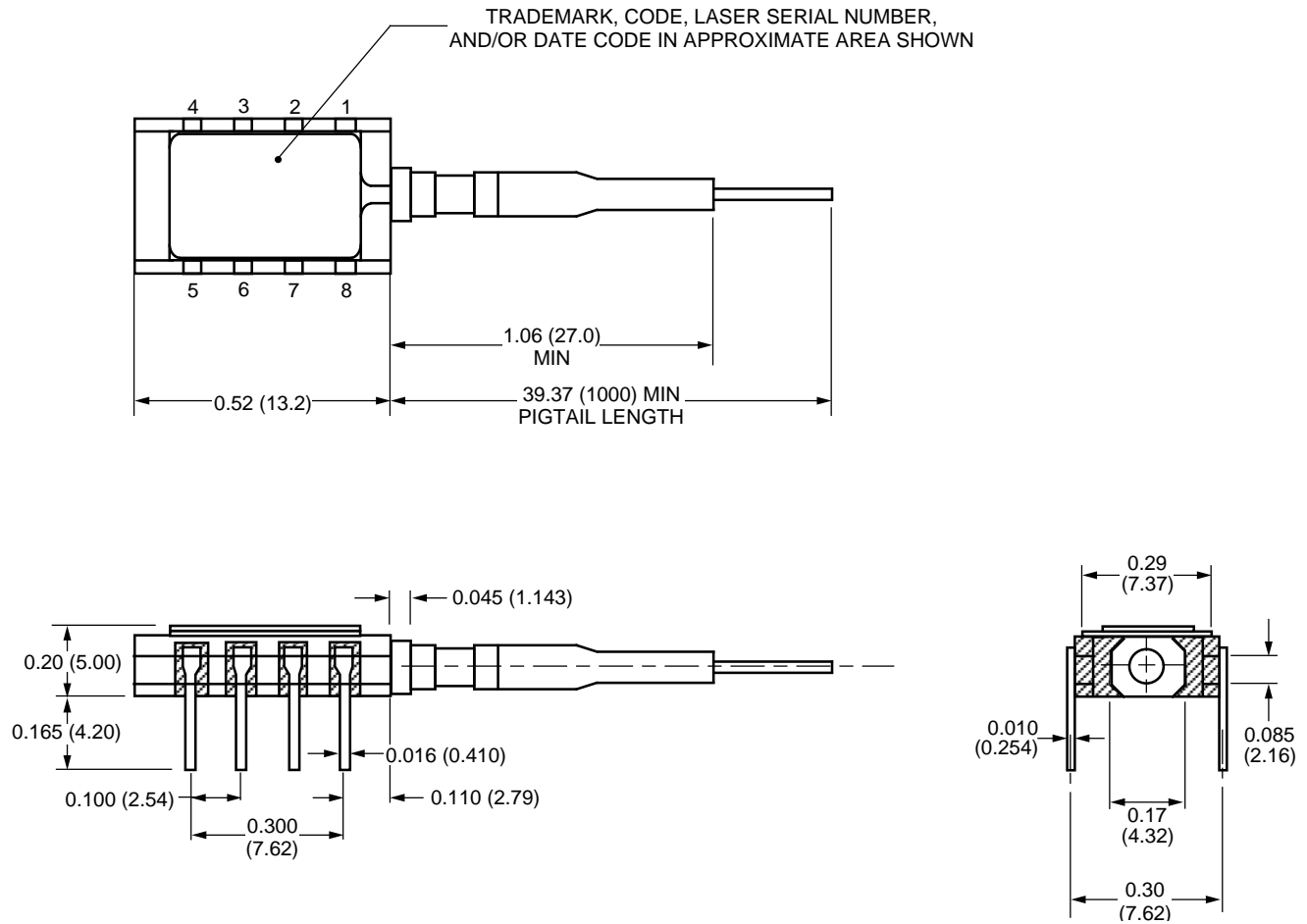

1-899.f

Qualification Information

The D571-Type Laser Module is scheduled to complete the following qualification tests and meets the intent of *Telcordia Technologies* TR-NWT-000468 for interoffice environments and TA-TSY-000983 for outside plant environments.

Table 3. D571-Type Laser Module Qualification Test Plan

Qualification Test	Conditions	Sample Size	Reference
Mechanical Shock	500 G for P/F 1,500 G for information	11	MIL-STD-883 Method 2002
Vibration	20 g, 20 Hz—2,000 Hz	11	MIL-STD-883 Method 2007
Solderability	—	11	MIL-STD-883 Method 2007
Thermal Shock	Delta T = 100 °C	11	MIL-STD-883 Method 2003
Fiber Pull	1 kg; 3 times for P/F 2 kg; 3 times for information	11	<i>Telcordia Technologies</i> 983
Accelerated (Biased) Aging	85 °C, 5,000 hrs.	25	<i>Telcordia Technologies</i> 983 Section 5.18
85 °C Storage	1,000 hrs. for provisional qual. 2,000 hrs. for P/F 5,000 hrs. for information	11	<i>Telcordia Technologies</i> 983
Temperature Cycling	500 cycles for P/F 1,000 cycles for information	11	<i>Telcordia Technologies</i> 983 Section 5.20
Cyclic Moisture Resistance	10 cycles for P/F 20 cycles for information	11	<i>Telcordia Technologies</i> 983 Section 5.23
Damp Heat	40 °C, 95% RH 1,000 hrs. for provisional qual. 1,344 hrs. for P/F	11	MIL-STD-202 Method 103
Internal Moisture	<5,000 ppm water vapor	11	MIL-STD-883 Method 1018
Flammability	—	—	TR357 Sec. 4.4.2.5
ESD Threshold	—	6	<i>Telcordia Technologies</i> 983 Section 5.22

Laser Safety Information

Class IIIb Laser Product

FDA/CDRH Class IIIb laser product. All versions are Class IIIb laser products per CDRH, 21 CFR 1040 Laser Safety requirements. All versions are Class IIIb laser products per IEC* 60825-1:1993. The device has been certified with the FDA under accession number 8720010.

This product complies with 21 CFR 1040.10 and 1040.11.

8.3/125 μm single-mode fiber pigtail and connector (optional)

Wavelength = 1.5 μm

Maximum power = 10 mW

Because of size constraints, laser safety labeling is not affixed to the module but attached to the outside of the shipping carton.

Product is not shipped with power supply.

Caution: Use of controls, adjustments, and procedures other than those specified herein may result in hazardous laser radiation exposure.

* IEC is a registered trademark of The International Electrotechnical Commission.

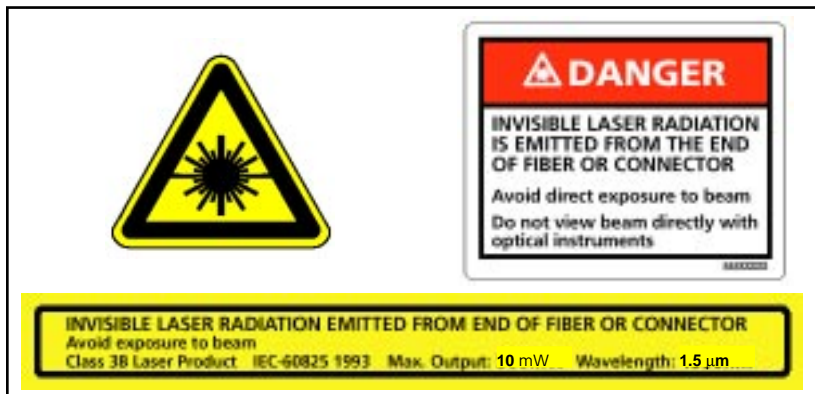

Ordering Information

Table 4. Ordering Information

Device Code	Comcode	Pfiber	Wavelength	Connector*	Operating Case Temperature Range ($^{\circ}\text{C}$)
D571-10A	108401118	1.0 mW	1550 nm	SC-PC	-40 to +85
D571-10F	108401068	1.0 mW	1550 nm	FC-PC	-40 to +85
D571-10N	108401142	1.0 mW	1550 nm	none	-40 to +85
D571-11A	108401159	1.0 mW	1550 nm	SC-PC	-10 to +70
D571-11F	108401175	1.0 mW	1550 nm	FC-PC	-10 to +70
D571-11N	108401191	1.0 mW	1550 nm	none	-10 to +70
D571-20A	108217068	2.0 mW	1550 nm	SC-PC	-40 to +85
D571-20F	108401217	2.0 mW	1550 nm	FC-PC	-40 to +85
D571-20N	108401233	2.0 mW	1550 nm	none	-40 to +85
D571-21A	108401241	2.0 mW	1550 nm	SC-PC	-10 to +70
D571-21F	108401266	2.0 mW	1550 nm	SC-PC	-10 to +70
D571-21N	108401282	2.0 mW	1550 nm	none	-10 to +70
D571C20A	108469743	2.0 mW	1510 nm	SC-PC	-40 to +85
D571C20F	108469768	2.0 mW	1510 nm	FC-PC	-40 to +85
D571C20N	108469784	2.0 mW	1510 nm	none	-40 to +85
D571C21A	108469792	2.0 mW	1510 nm	SC-PC	-10 to +70
D571C21F	108469818	2.0 mW	1510 nm	FC-PC	-10 to +70
D571C21N	108469834	2.0 mW	1510 nm	none	-10 to +70

* Connectors will meet *Telcordia Technologies* GR-326-CORE.

For additional information, contact your Microelectronics Group Account Manager or the following:

INTERNET: <http://www.lucent.com/micro>, or for Optoelectronics information, <http://www.lucent.com/micro/opto>

E-MAIL: docmaster@micro.lucent.com

N. AMERICA: Microelectronics Group, Lucent Technologies Inc., 555 Union Boulevard, Room 30L-15P-BA, Allentown, PA 18103
1-800-372-2447, FAX 610-712-4106 (In CANADA: **1-800-553-2448**, FAX 610-712-4106)

ASIA PACIFIC: Microelectronics Group, Lucent Technologies Singapore Pte. Ltd., 77 Science Park Drive, #03-18 Cintech III, Singapore 118256
Tel. (65) 778 8833, FAX (65) 777 7495

CHINA: Microelectronics Group, Lucent Technologies (China) Co., Ltd., A-F2, 23/F, Zao Fong Universe Building, 1800 Zhong Shan Xi Road, Shanghai 200233 P. R. China **Tel. (86) 21 6440 0468, ext. 316**, FAX (86) 21 6440 0652

JAPAN: Microelectronics Group, Lucent Technologies Japan Ltd., 7-18, Higashi-Gotanda 2-chome, Shinagawa-ku, Tokyo 141, Japan
Tel. (81) 3 5421 1600, FAX (81) 3 5421 1700

EUROPE: Data Requests: MICROELECTRONICS GROUP DATALINE: **Tel. (44) 7000 582 368**, FAX (44) 1189 328 148
Technical Inquiries: OPTOELECTRONICS MARKETING: **(44) 1344 865 900** (Ascot UK)

Lucent Technologies Inc. reserves the right to make changes to the product(s) or information contained herein without notice. No liability is assumed as a result of their use or application. No rights under any patent accompany the sale of any such product(s) or information. *FastLight* is a trademark of Lucent Technologies Inc.





ООО «НИОКРсистемс» - это оперативные поставки широкого спектра электронных компонентов отечественного и импортного производства напрямую от производителей и с крупнейших мировых складов. Реализуемая нашей компанией продукция насчитывает более полумиллиона наименований.

Благодаря этому наша компания предлагает к поставке практически не ограниченный ассортимент компонентов как оптовыми, мелкооптовыми партиями, так и в розницу.

Благодаря развитой сети поставщиков, помогаем в поиске и приобретении экзотичных или снятых с производства компонентов.

Наша компания это:

- Гарантия качества поставляемой продукции
- Широкий ассортимент
- Минимальные сроки поставок
- Техническая поддержка
- Подбор комплектации
- Индивидуальный подход
- Гибкое ценообразование
- Работаем по 275 ФЗ